

**Santana 20 Class
Association**

Yearbook
2020-21

Membership Roster

—

Articles of Association

—

Bylaws

—

Measurer's Rules & Manual

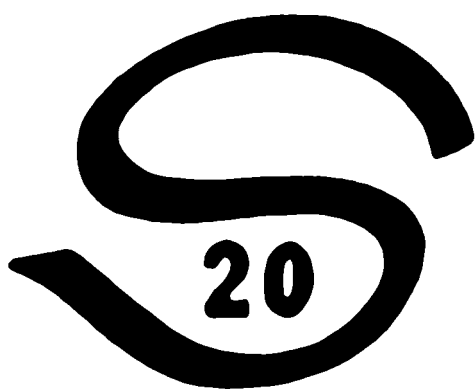
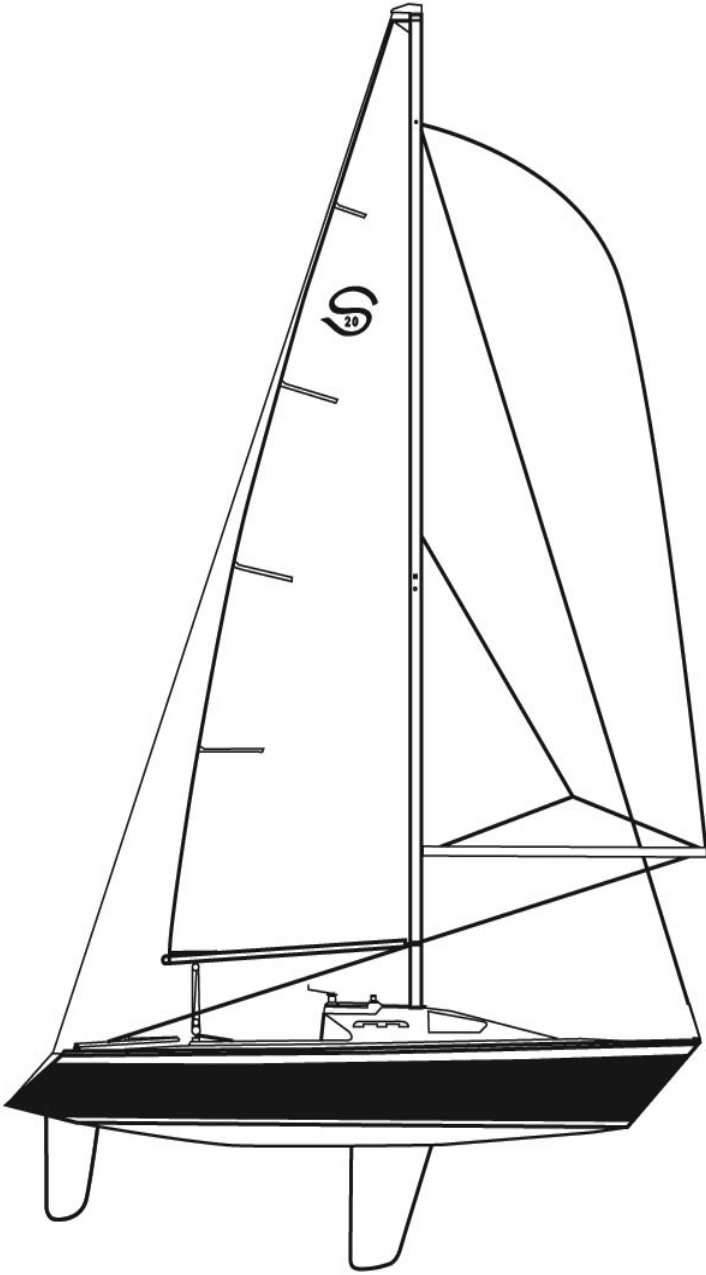

Table of Contents

| | |
|--|------------|
| Executive Officers | 5 |
| Class Champions | 6 |
| District Map | .11 |
| Part 1 – Roster of Fleets | .12 |
| | |
| Part II – Articles of Association | .14 |
| Official Rig Plan | 23 |
| Boat Layout Illustrations | .26 |
| Santana 20 Characteristics | .28 |
| Bylaws | .30 |
| Measurer’s Rulings | .40 |
| Fleet Measurer’s Manual | .44 |
| | |
| Sail Measurer’s Worksheet | .52 |
| Winged Keel Dimensions | .54 |
| Guidelines for Class Championships | .55 |



2019 Executive Officers

| | | | |
|-----------------------|------------------|--|--------------|
| President | Ted Walkup | tedwalkup@hotmail .com | 541-543-6088 |
| Vice President | Ryan Southworth | Southworthryan@gmail.com | 541-520-3044 |
| Secretary | Jim Bogner | readyjimm@gmail.com | 303-999-9140 |
| Treasurer | Walter Stevens | wltstevens@gmail .com | 424-653-8055 |
| Class Measurer | Glen Hughes | Glenhughes314@gmail.com | 541-968-9644 |
| Director- West Region | Mike McKeever | mijamck@gmail .com | 303-589-0815 |
| Hon. Direct/Builder | Tom Schock | | |
| Past President | Russell Petersen | russ9993@comcast.net | 541-914-9993 |
| Webmaster | Gordon Mattatall | gsp@pacinfo .com | 541-913-3400 |
| Communications | Lyle Mayer | guanoguy@comcast.net | 541-915-8194 |

Past Santana 20 Champions

| Year | Host Fleet | Winners |
|-------------|------------------------------|-----------------------------------|
| 1977 | Fleet 2, Balboa Y .C . | 1 st – Tim Hogan |
| 1978 | Fleet 4, Richmond Y .C . | 1 st – Bill Herrschaft |
| 1979 | Fleet 2, Newport Harbor Y .C | 1 st – Bill Herrschaft |

| | | |
|------|--------------------------------|---|
| 1980 | Fleet 7, Coronado Y .C | 1 st – Harry Pattison |
| 1981 | Fleet 5, Fresno Y .C . | 1 st – Harry Pattison |
| 1982 | Fleet 21, Canyon Lake Y .C . | 1 st – Tim Hahnke |
| | | 2 nd – Mike Rockoff |
| | | 3 rd - Blake Quinn |
| 1983 | Fleet 7, Coronado Y .C . | 1 st - Jane Schock |
| | | 2 nd - Doug Teulie |
| | | 3 rd - Mike Cusack |
| 1984 | Fleet 9, Windjammers, Y .C | 1 st – Harry Pattison |
| | | 2 nd – Jane Schock |
| | | 3 rd – Mike Cusack |
| 1985 | Fleet 17, Oklahoma City Y .C . | 1 st – Harry Pattison |
| | | 2 nd – Rick Thompson |
| | | 3 rd – Billy Dawson |
| 1986 | Fleet 19, Eugene Y .C . | 1 st – Harry Pattison |
| | | 2 nd - Scott Cullen |
| | | 3 rd - Mark Verutti |
| 1987 | Fleet 23, Valle De Bravo Y .C. | 1 st - Jane Schock & Bill Herrschaft |
| | | 2 nd - Harry Pattison |
| | | 3 rd – Mike Rockoff |
| 1988 | Fleet 1, Santa Monica Y .C | 1 st - Jane Schock & Bill Herrschaft |
| | | 2 nd - Charles Howard |
| | | 3 rd - Chris Winnard |
| 1989 | Fleet 27, Klamath Y .C . | 1 st - Bart Hackworth |
| | | 2 nd - Chris Winnard |
| | | 3 rd - Harry Pattison |
| 1990 | Fleet 31, Offshore Y .C | 1 st - Bart Hackworth |
| | | 2 nd – Mike Rockoff |
| | | 3 rd – Mike Cheda |
| 1991 | Fleet 19, Eugene Y .C . | 1 st – Mike Sherlock |

| | | |
|------|------------------------------|--|
| | | 2 nd – Mike Rockoff |
| | | 3 rd - Paul Stephens |
| | | |
| 1992 | Fleet 6, Coronado Y .C | 1 st – Mike Sherlock |
| | | 2 nd – Chic Parsons |
| | | 3 rd – Chris Winnard |
| 1993 | Fleet 1, Santa Monica Y .C . | 1 st – Chris Winnard |
| | | 2 nd - Greg Gran |
| | | 3 rd – Jon Kilgore & Bill Jenkins |
| 1994 | Fleet 28, Lake Dillon Y .C . | 1 st – Vern Bybee |
| | | 2 nd - Mick Sage |
| | | 3 rd – Doug Smith |
| 1995 | Fleet 15, Eagle Point Y .C . | 1 st - Chris Winnard |
| | | 2 nd – Ron Fish |
| | | 3 rd – Micj Sage |
| 1996 | Fleet 19, Eugene Y .C . | 1 st – Paul Stephens |
| | | 2 nd – Chris Winnard |
| | | 3 rd – John Franklin |
| 1997 | Fleet 7, Mission Bay Y .C . | 1 st – Tom Schock |
| | | 2 nd – Charlie Ogletree |
| | | 3 rd – Chris Winnard |
| 1998 | Fleet 15, Rush Creek Y .C . | 1 st – Chris Winnard |
| | | 2 nd – Tom Schock |
| | | 3 rd – Terry Schertz |
| 1999 | Fleet 28, Casper Boat Club | 1 st – Paul Stephens |
| | | 2 nd – Tom Schock |
| | | 3 rd – Travis Wilson & Rick Harris |
| 2000 | Fleet 2, Balboa Y .C . | 1 st - Willem VanWaay & Travis Wilson |
| | | 2 nd – Bruce Golison |

| | | |
|------|---|------------------------------------|
| | | 3 rd – Kerry Poe |
| 2001 | Fleet 19, Klamath Y .C . | 1 st – Charlie Ogletree |
| | | 2 nd – Chris Winnard |
| | | 3 rd – Charles Witcher |
| 2002 | Fleet 1, Del Rey Y .C . | 1 st - Chris Winnard |
| | | 2 nd – Charlie Ogletree |
| | | 3 rd – Bruce Golison |
| 2003 | Fleet 12, Fresno Y .C . | 1 st - Charlie Ogletree |
| | | 2 nd - Willem VanWaay |
| | | 3 rd – Bruce Golison |
| | | |
| | | |
| 2004 | Fleets 28 & 13, Alamitas Bay Y .C | 1 st – Bruce Golison |
| | | 2 nd – Chris Winnard |
| | | 3 rd – Williem VanWaay |
| 2005 | Fleets 19 & 16, Columbia Gorge Racing Assoc | 1 st - Bruce Golison |
| | | 2 nd – Chris Winnard |
| | | 3 rd – Lance Purdy |
| 2006 | Fleet 7, Coronado Y .C . | 1 st – Payson Infelise |
| | | 2 nd – Chris Winnard |
| | | 3 rd – Eric Jownacke |
| 2007 | Fleet 37, Windy Crest SC | 1 st – Bruce Golison |
| | | 2 nd – Eric Kownacki |
| | | 3 rd – Kenny Baggett |
| 2008 | Fleet 19, Eugene Y .C. | 1 st - Eric Kownacki |
| | | 2 nd – Jim Martinez |
| | | 3 rd – Chris Winnard |
| 2009 | Fleet 7, Mission Bay Y .C. | 1 st – Chris Winnard |
| | | 2 nd – Eric Kownacki |
| | | 3 rd – Chris Snow |

| | | |
|------|---|------------------------------------|
| 2010 | Fleet 12, Huntington Lake, CA | 1 st – Bruce Golison |
| | | 2 nd – Ron Fish |
| | | 3 rd – Eric Kownacki |
| 2011 | Fleet 17, Oklahoma City Boat Club | 1 st - Eric Kownacki |
| | | 2 nd – Ron Fish |
| | | 3 rd – Britt Williams |
| 2012 | Fleet 19, Eugene Y .C, OR | 1 st – Chris Winnard |
| | | 2 nd – Gordon Mattatall |
| | | 3 rd – Eric Kownacki |
| 2013 | Fleet 2, Alamitos Bay Y .C . Long Beach, CA | 1 st – Eric Kownacki |
| | | 2 nd – Glen Hughes |
| | | 3 rd – Ryan Lorence |
| 2014 | Fleet 19, Eugene Yacht Club, OR | 1 st – Eric Jownacki |
| | | 2 nd - Paul Stephens |
| | | 3 rd – Gordon Mattatall |
| 2015 | Fleet 19, Eugene Yacht Club, OR | 1 st – Eric Knowacki |
| | | 2 nd – Gordon Mattatall |
| | | 3 rd – Paul Stephens |
| 2016 | Fleet 19, Klamath Yacht Club, OR | 1 st - Eric Knowacki |
| | | 2 nd – Ron Fish |
| | | 3 rd – Gordon Mattatall |
| 2017 | Fleet 28, Dillon Yacht Club, CO | 1 st - Payson Infelise |
| | | 2 nd – Frank Keesling |
| | | 3 rd - Ron Fish |
| 2018 | Fleet 19 Rogue Yacht Club, OR | 1 st – Ron Fish |
| | | 2 nd – Gordon Mattatall |
| | | 3 rd – Paul Stephens |

| | | |
|------|----------------------|---------------------|
| 2019 | Fleet 19- Eugene, OR | 1. Andrew Kerr |
| | | 2. Gordon Mattatall |
| | | 3. Ron Fish |
| | | |
| | | |
| | | |
| | | |
| | | |
| | | |
| | | |
| | | |
| | | |
| | | |
| | | |
| | | |
| | | |
| | | |
| | | |
| | | |
| | | |
| | | |
| | | |
| | | |

District Map

Error! Reference source not found.

Roster of Fleets

(Currently ACTIVE Fleets are bold)

| | |
|------------|---|
| Fleet – 1 | Marina Del Rey, California |
| Fleet – 2 | Newport Beach, California |
| Fleet – 3 | Spokane, Washington |
| Fleet – 4 | San Francisco, California |
| Fleet – 5 | Joaquin Valley, California |
| Fleet – 6 | Grosse Ile, Michigan |
| Fleet – 7 | San Diego, California |
| Fleet – 8 | Indianapolis, Indiana |
| Fleet – 9 | Lake Tahoe, California |
| Fleet – 10 | Columbia River, Portland, Oregon |
| Fleet – 11 | Kansas City, Missouri |
| Fleet – 12 | Folsom Lake, California |
| Fleet – 13 | Long Beach, California |
| Fleet – 14 | |
| Fleet – 15 | |
| Fleet – 16 | Seattle, Washington |
| Fleet – 17 | Oklahoma City, Oklahoma |
| Fleet – 18 | |
| Fleet – 19 | Eugene, Oregon |
| Fleet – 20 | Sarasota, Florida |

| | |
|------------|--------------------------------|
| Fleet – 21 | Sequin/San Antonio, Texas |
| Fleet – 22 | Galveston Bay, Texas |
| Fleet – 23 | Valle De Bravo, Mexico |
| Fleet – 24 | Okanogan, Canada |
| Fleet – 25 | Flathead Lake, Montana |
| Fleet – 26 | Atlanta, Georgia |
| Fleet – 27 | Klamath Falls, Oregon |
| Fleet – 28 | Rocky Mountain, Colorado |
| Fleet – 29 | Canadaigua Lake, New York |
| Fleet – 30 | Salt Lake, Utah |
| Fleet – 31 | Channel Islands, California |
| Fleet – 32 | Lake Region Saling Club, Maine |
| Fleet – 33 | Columbia, South Carolina |
| Fleet – 34 | Olympia, Washington |
| Fleet – 35 | Phoenix, Arizona |
| Fleet – 36 | Perry Lake, Kansas |
| Fleet – 37 | Tulsa, Oklahoma |

Part II Articles, Bylaws, and Measurements

Articles of Association

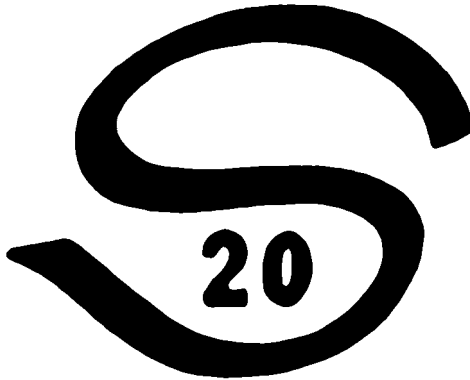

ARTICLE I - NAME

The name of this Association shall be SANTANA 20 CLASS ASSOCIATION, hereinafter called the Association.

ARTICLE II - OBJECT

The object of the Association shall be to maintain the one-design features of the Santana 20 according to its plans and specifications and these Articles and Bylaws, and to promote Class racing and such other yachting activities as will benefit the members of the Association.

ARTICLE III - POLICY

- 1 . To cooperate with other yachting organizations and, in return, to insist on strict observance and compliance with the rules of the Santana 20 Class Association.
- 2 . To keep the cost of acquisition and upkeep of Santana 20 class sloops within modest limits without sacrificing high standards of performance and seaworthiness.
- 3 . To promote and maintain a one-design class of Santana 20 sloops divided into two types represented by the fin keel and the winged keel versions as produced by the W.D. Schock Corporation and licensees in which racing shall be to determine the skill of the skipper and the crew under uniform rules and specifications .

ARTICLE IV - JURISDICTION

- 1 . The Association has jurisdiction over all Santana 20 Class activities. Its Articles and Bylaws shall govern all Santana 20 Class races regardless of by whom they are held and are binding upon all members and Fleets.
- 2 . Permission must be obtained from the Association prior to eliminating or deviating from any requirement of these Articles and Bylaws in racing a Santana 20 Class sloop
- 3 . All events involving racing within the territorial waters of a Fleet shall be sanctioned by the Fleet through its elected Officers
- 4 . All disputes or issues involving the interpretation of these Articles and Bylaws shall be submitted in writing to the Governing Board of the Association for resolution and the decisions of the Governing Board shall be final and binding upon all Officers, Members, and Fleets of the Association.
- 5 . The Association shall not be liable for any debts contracted by its Officers, Fleet Officers, or members other than expenditures authorized by the budget or upon written order of the President and Treasurer.
- 6 . The Association reserves the right to declare ineligible any yacht which does not conform to the SPIRIT as well as the letter of these Articles and Bylaws, and the specifications and drawings of the Santana 20.

ARTICLE V - FLEET CHARTERS

- 1 . The Fleet is a territorial unit open to all eligible persons within its area.
- 2 . Fleet Charters may be granted upon application to the Governing Board by two (2) or more owners who are Members in good standing of the Association and not within the territory of any organized Fleet.

ARTICLE VI - GOVERNING BOARD

- 1 . The Board of Directors shall be known as the Governing Board; and shall consist of all executive officers, the immediate past president, the district secretaries and the other directors specified in Article VII and shall serve for a term as specified therein.
- 2 . For purposes of doing business, a quorum shall consist of a majority of the Executive Board.
- 3 . The Governing Board shall conduct all business, determine policy of the Santana 20 Class Association, and shall serve as the last court of appeals in disputes involving these Articles and Bylaws.
- 4 . The Governing Board shall meet at such time and place as may be specified by the President or a majority of the members of the Governing Board.
- 5 . The Governing Board has the authority to enforce its decisions by suspension of entire Fleets or individual members. The Board shall sanction or ban races, grant or revoke Fleet Charters and suspend members guilty of gross violation of rules or unsportsmanlike conduct. Its rulings shall be binding and final. A three-fourths majority vote shall decide such issues.

ARTICLE VII - EXECUTIVE BOARD

- 1 . The Executive Officers and Directors of the Santana 20 Class Association and their respective duties shall be as follows:
 - a) **PRESIDENT** - The President is the Chief Executive. He shall preside at meetings, serve as Chairman of the Governing Board, rule on procedure and jurisdiction, summarize decisions, appoint special committees, determine the time and place for meetings of the Governing Board and shall disperse funds in the absence of the Treasurer and with the

approval of a three-fourths majority vote of the Governing Board .

- b) VICE PRESIDENT - The Vice President shall officiate in the absence of the President and is in charge of the Class Championship Regatta.
- c) SECRETARY - The Secretary shall handle all correspondence, record the minutes of meetings and maintain an accurate and current record of members, Fleets and Fleet Officers. He shall notify the membership of special events, decisions affecting policy, banned races, suspended members and/or Fleets and ineligible Santana 20 sloops.
- d) TREASURER - The Treasurer shall deposit funds and disperse funds only on the order of the President with the approval of the Governing Board.
- e) CHIEF MEASURER - The Chief Measurer shall be in charge of all certified measurers on the Measurement Committee assembled for the Class Championship Regatta. He shall grant or reject all measurement certificates, issue duplicates and answer all questions from Fleet Measurers regarding measurement rules. He shall interpret the rules and regulations on matters not specifically covered in the official plans and specifications. Such rulings shall be subject to approval of the Governing Board. The Chief Measurer shall not approve changes in construction specifications, sail plan or rigging. Rulings of the Chief Measurer approved by the Board shall be posted on the National Class website.
- f) REGIONAL DIRECTORS— There shall be other Directors, defined by geographical region, that shall have Board voting privileges and shall also act as District Secretaries if none have been appointed. They shall be charged with the care, membership growth, and regatta coordination of the Fleets within their Region. They shall also evaluate and make recommendations to the Governing Board regarding:
 - 1) Changes in the Articles and Bylaws of the Association.
 - 2) Organization of special committees, including publicity, nominations, activities and membership.

g) SCHOCK COMPANY REPRESENTATIVE - In recognition of Tom Schock's services to the Santana 20 Class, he shall hold the office of Honorary Director permanently. He may vote.

- 2 . All officers and directors, excluding Tom Schock, shall be elected at the annual meeting of the Association for a term commencing with the annual meeting and expiring at the conclusion of the next annual meeting. Each shall be nominated, seconded and voted upon separately by the fleet delegates in the order named. Candidates shall be presented by the Chairman of the Nominating Committee who shall be the Immediate Past President.
- 3 . An Executive Officer or Director may resign his office by sending written notice to the Board of Directors. Any such resignation shall become effective upon acceptance of the Board of Directors.
- 4 . Any member of the Board of Directors who fails to attend three (3) consecutive Board meetings without adequate excuse to the President prior to the meeting shall be deemed to have requested resignation from the Board.
- 5 . A vacancy occurring in any elective office, except that of President shall be filled by appointment by the President with approval of the Board for the unexpired term. In case of a vacancy in the office of President, the Vice President shall become President for the unexpired term.

ARTICLE VIII – DISTRICTS

- 1 . A District shall be a geographical area as defined by the Board of Directors.
- 2 . District Officers:
 - a) DISTRICT SECRETARY - The District Secretary shall be a member of the Governing Board and shall have general supervision over all Santana 20 Class Association activities in the District. They shall coordinate policy and decisions of the Governing Board with each Fleet in the District. The District Secretary shall be selected by the Governing Board and shall serve during the ensuing year.

ARTICLE IX – MEETINGS

1. The Association shall conduct an annual meeting at such time and place as may be determined by the Governing Board. The Governing Board shall set a time and place for the Annual Meeting which will coincide with the time and place of the Class Championship Regatta.
2. Special meeting of the Association may be called by the Governing Board and shall be called when petition in writing by at least twenty-five percent (25%) of the active Fleets of the Association to the Governing Board. The time and place of special meetings in all cases shall be set by the Governing Board.
3. Notice shall be posted on the Class website and must be sent to the last recorded Fleet Captain of each Fleet and e-mailed or deposited into the mail not later than fifteen (15) days before the time of such meeting. The notice of a meeting shall describe the purpose of the meeting and the business to be transacted at such meeting. If the business of the meeting calls for voting by mail or e-voting, arrangements for such voting shall be made according to the rules established by the Governing Board.
4. Representatives of one-half of the Fleets in good standing shall constitute a quorum at meetings. If a quorum exists at Roll Call, it exists throughout the session of the meeting.
5. The membership of each Fleet shall select and instruct a delegate. If unable to send a delegate, the Fleet shall sign and deliver to the Secretary of the Association, a duly authorized proxy to present the Fleet's views and cast its votes at all meetings. If any Fleet does not send a delegate or deliver a proxy as set forth above, the Governing Board shall cast the votes to which such fleet is entitled.
6. Any number of alternates or proxies may be named, but the first in order present shall be the only entitled to cast the Fleet's votes. Only those alternates or proxies properly certified in writing by the proper Fleet officers will be recognized.
7. Each Fleet shall be entitled to cast one vote for each Santana 20 Class sloop enrolled in that Fleet, which has been properly recorded with the Association by an active member in good standing. No Fleet is entitled to more than thirty-three and one third

percent (33 1/3%) of the total number of votes cast. No more than one vote shall be allowed for any one member no matter how many Santana 20 Class sloops he may own. Membership books close thirty (30) days before the annual meeting or as ordered by the Governing Board.

8. Members may be heard, but only accredited delegates, proxies, alternates and unattached members shall vote on motions. All Fleet delegates or unattached members must vote on each motion unless excused by the Chairman of the Annual Meeting. A majority of votes cast shall decide all questions not otherwise stipulated and the Chair shall cast the one deciding vote in case of a tie and may fix a time limit on speakers and debate on motions.

9. The order of business at annual meetings shall be:

- Call to Order
- Roll Call of Fleets
- Minutes of Last Meeting
- Report of Executive Officers
- Report of Charters Granted and Revoked
- Ratification of Governing Board Rulings
- Unfinished Business
- New Business
- Election of Officers
- Adjournment

ARTICLE X – AMENDMENTS

1. These Articles and Bylaws may never be suspended but may be amended at any meeting of the Association by a fifty-one percent (51%) majority vote of all paid members in good standing through their fleet delegates at the meeting.

2. Proposed amendments of the Articles of Association and Bylaws shall be submitted in writing to the Secretary of the Association not later than forty-five (45) days before the date such amendments are to be considered at the Annual Meeting or at any special meeting of the Association and must be included in the notice which shall be posted to the general membership on the National Class web page not less than thirty (30) days prior to the date of the meeting .

- 3 . The Governing Board shall have the authority to simplify, clarify or correct the language of any Article hereof or amendment hereto so long as the intent and purpose thereof remain unchanged.
- 4 . Proposed amendments to these Articles and Bylaws shall be submitted by the Governing Board.
- 5 . A proposed change may be initiated by a majority vote of the delegates present at the Annual Class Meeting. The proposed change will be voted on at the next Annual Class Meeting.
- 6 . These Articles and Bylaws may be amended by the written consent of the majority of members. Fleets shall give such consent only upon vote of members at a meeting thereof or written consent of a majority of the fleet.

ARTICLE XI – MEMBERSHIP

- 1 . Applications for membership in the Association shall be made through the Fleet in whose jurisdiction or territory the applicant normally sails; and if no Fleet has jurisdiction over such territory, then such application shall be directly to the Association or through the Class website. A member of this Association not in a fleet shall be known as an Unattached Member.
- 2 . A member while in good standing of this Association shall be eligible to race in any sanctioned race. He/She shall be required to conform to the local Fleet rules and regulations and shall hold an "Official Certificate of Measurement" and a current Santana 20 Class Association membership card.
- 3 . Any member may be expelled from the Santana 20 Class Association only by three-quarters (3/4) vote at an Annual Meeting.
- 4 . Except for participation in a Class Championship Regatta, a participant in a sanctioned event shall be allowed thirty (30) days from the time he acquired his Santana 20 to meet all measurement and membership requirements of the Association, but shall be subject to protest and, if that boat, equipment, and sails do not meet the requirements of these Bylaws, disqualification .
- 5 . Members who are delinquent in either Fleet or Association dues shall be ineligible and disqualified from racing until the dues are

paid. Members who race when delinquent in their dues may be suspended.

- 6 . When a member ceases to be a Santana 20 Class sloop owner, current membership status shall be retained, along with racing eligibility, until the end of the calendar period when his dues are payable again.
- 7 . A member cannot belong to more than one Fleet at one time nor can a Santana 20 Class sloop be registered in more than one Fleet at one time.
- 8 . Membership shall be of three classes:
 - a) REGULAR MEMBER – An owner of a qualified Santana 20 Class sloop who shall have voting privileges in the Association. An owner must be able to prove ownership in the boat.
 - b) ASSOCIATE MEMBER – Any interested person who pays dues who shall not have voting privileges. An Associate Member shall be eligible to skipper a Santana 20 only if they are registered with the Association by a Regular Member.
 - c) AFFILIATE MEMBER – Any interested person who normally sails outside the U.S. An Affiliate Member is ineligible to receive the Yearbook; is ineligible to enter fleet, district, or regional championship regattas held within U.S. boundaries; and is ineligible to enter the Class Championship Regatta.
- 9 . Only one Regular Member per boat shall be eligible to vote. Each membership shall include the member's spouse and children under the age of 18.
- 10 . "GUEST" - A skipper who is not an Association Member may be a guest of one sponsoring Santana 20 Fleet for one regatta or series per year, with the exception of any event of the status of fleet championship or higher. The guest must obtain the approval of the sponsoring Fleet Captain or Secretary prior to racing in the regatta or series. Guest skipper names will be submitted to the Association Secretary within one (1) month after the regatta or series begins. The boat used by a guest must conform to measurements and be owned by an Association member.

ARTICLE XII – DUES

- 1 . 1. The annual dues of the Association shall be:

- a) Regular Member: \$55 .00
 - b) Associate Member: \$25 .00
 - c) Affiliate Member: \$15 .00
- 2 . The Governing Board may approve discounts and incentives to increase membership.
 - 3 . Fleet dues shall be prescribed by the Fleet and shall be retained by that Fleet.
 - 4 . Association dues may be collected by the Fleet Captain and forwarded to the Association Secretary with identification of Members and related yachts on or before October 15 of each year, or in the case of new Members, within fifteen (15) days of collection. Dues may also be paid through the Class website.
 - 5 . The Secretary of the Association shall issue current membership cards to all Members in good standing.

Official Rig Plan

| FROM BOTTOM OF MAST | TOLERANCE ($\pm 1/4''$) |
|-----------------------|---------------------------|
| Mast extrusion length | 26' 8" |
| Bottom of top band | 26' 4" |
| Upper tang bolt max | 24' 3/4" |

| | |
|--------------------------------------|---------------------------|
| Spinnaker halyard exit max | 23' 8" |
| Spreader | 11' 9" |
| Lower tang bolt max | 11' 6" |
| Spinnaker pole height max | 5' 5-1/2" |
| To top of lower band | 1' 10" |
| BETWEEN MAST BANDS | TOLERANCE (± 1/4") |
| Main luff | 24' 6" |
| FROM AFT SIDE OF MAST | TOLERANCE (± 1/4") |
| To inside of boom band | 7' 0" |
| FROM FORWARD SIDE OF MAST | TOLERANCE (± 1/4") |
| To middle of stem forestay hole | 8' 2-1/4" |
| FROM OUTER EDGE TO OUTER EDGE | TOLERANCE (± 1/4") |
| Spinnaker pole length max | 8' 2" |
| FROM CHAINPLATE AFT | TOLERANCE (± 1/4") |
| To aft lower track max | 1' 3" |
| FROM OUTBOARD EDGE OF NONSKID | TOLERANCE (± 1/4") |
| To aft lower track min | 1' 0-1/2" |
| FROM CENTER OF RUDDERPOST | TOLERANCE (± 1/4") |
| To center of traveller max | 4' 5-1/4" |
| To center of traveller min | 3' 5" |
| FROM AFT SIDE OF MAST | TOLERANCE (± 1/4") |
| To mainsheet bail max | 7' |
| To mainsheet bail min | 5' 8" |
| FROM TRANSOM | TOLERANCE (± 1/4") |
| To trailing edge of keel | 9' 9" |



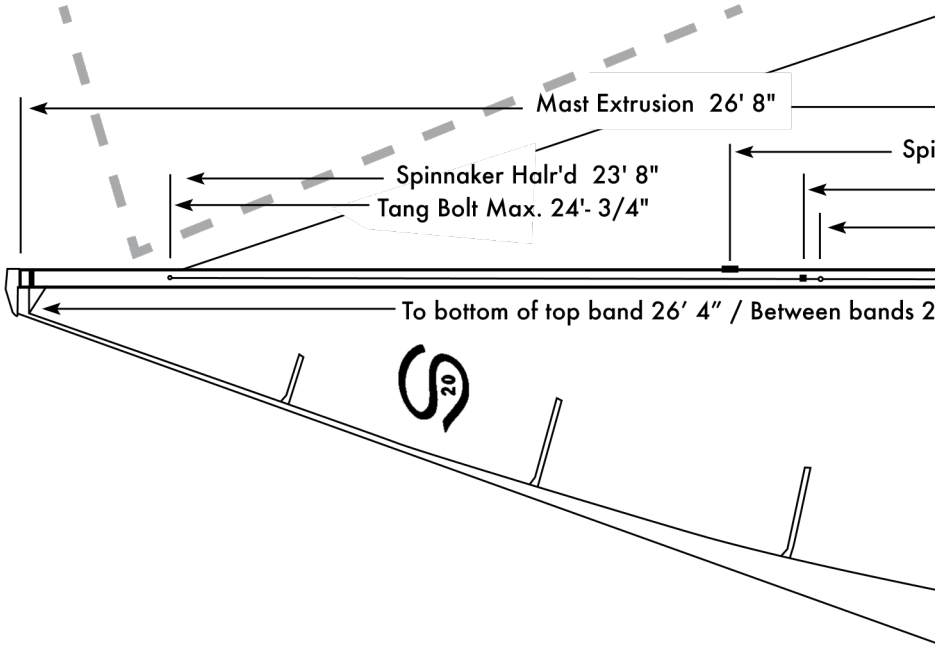
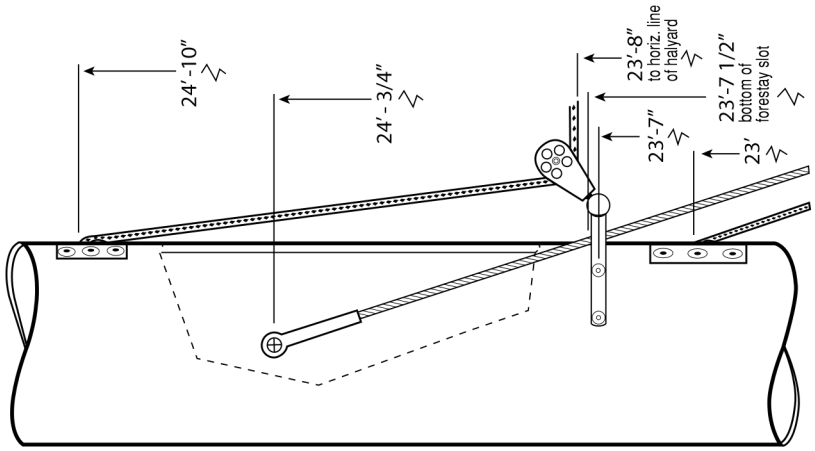

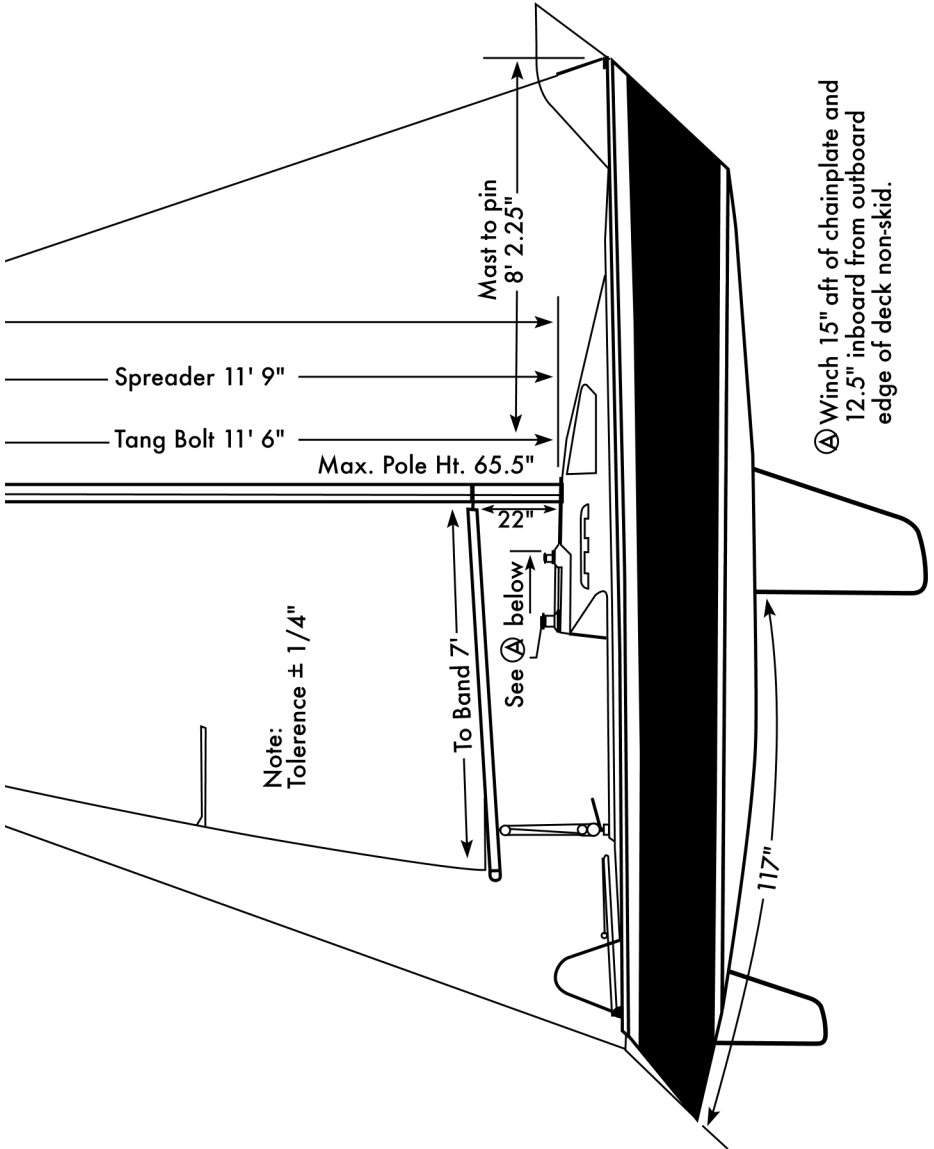
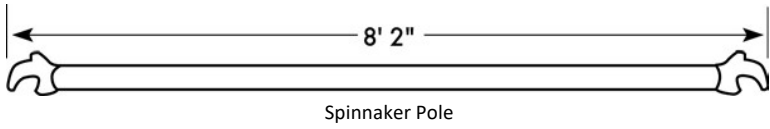

Santana 20 Characteristics

The following table shows what rig measurements must be made on a Santana 20 to validate a measurement certificate and comply with the Class Rules:

| | | |
|----------------------------|--------------------------|----------------|
| LOA 20' 2-1/2" | Displacement | .1530 lbs . |
| LWL 16' | Ballast - Fin | .550 lbs . |
| Beam 8' | Ballast - Wing | .600 lbs . |
| Draft - Fin 48" | Sail Area | .186 sq . ft . |
| Draft - Wing 32" | | |

FOR THE PURPOSE OF MAINTAINING FAIR SAILING, THE FOLLOWING MEASUREMENTS MUST BE MAINTAINED PLUS OR MINUS 3/8 INCHES ON THE RUDDER AND KEEL:

RUDDER

The thickness of the rudder section measured down from the top edge 3 inches is 2-1/16 inches.

The thickness of the rudder section measured down from the top edge 20 inches is 1-5/8 inches.

Intentional hollowing or changing of the cross section outside of a straight-line top to bottom is not allowed.

The gap between the top of the rudder and the hull and between the front edge of the rudder and the rudder post may be filled with any material provided this material does not extend out from the profile or section of the rudder.

FIN KEEL

The thickness of the keel section measured down from the hull 3 inches is 4 inches .

The thickness of the keel section measured down from the hull 20 inches is 3-3/16 inches .

Intentional hollowing or changing of the section outside of a straight line top to bottom is not allowed .

WINGED KEEL

The thickness of the keel section measured down from the hull 3 inches is 3 inches.

The thickness of the keel section measured down from the hull 16 inches is 3 inches.

The thickness of the wings measured 3 inches from the outboard tip is 2-5/8 inches.

The thickness of the wings measured 5-1/2 inches from the outboard edge is 3 inches.

Intentional hollowing or changing of the section is not allowed.

NOTE:

A hollow of 1/8 inches is permitted on a straight-line top to bottom of the keel and rudder. Under no conditions may the profile of the keel or rudder be extended.

The keel and rudder may be smoothed and made fair within the following provisions:

It is allowed to add material to the hull, keel, and rudder to fill depressions.

Bylaws

ARTICLE I - MEASUREMENT & REGISTRATION CERTIFICATES

1. Santana 20 Class sloops which meet all measurement requirements of the Association shall be issued a "Certificate of Measurement and Registration." Such measurement certificate shall be approved by the signatures of the Fleet Measurer, the Chief Measurer and the Secretary of the Association. Certificates shall expire and boats shall be completely re-measured after 5 years from the date of issue.
1. A yacht holding an official measurement certificate shall not be subject to re-measurement of protest, except where reasonable evidence is produced to show material alterations made subsequent to the granting of the certificate by the Governing Board.
2. Fleet Measurers shall be appointed by Fleet Officers and shall have authority only to measure and record measurements on the Certificate of Measurement and Registration Form as provided by the Association and in accordance with instructions from the Chief Measurer of the Association. Disputes between Fleet Measurers and Members concerning measurements shall be referred to the Chief Measurer of the Association who shall present such matters to the Governing Board with his/her recommendations.
3. A Fleet Measurer shall not measure his own yacht. Fleet Officers or their duly appointed representatives shall measure the yacht of the Fleet Measurer when necessary.
4. The Association Secretary shall be responsible for officially registering the certificates.
5. It is the policy of the Association to provide Measurement and Registration Certificates for those boats which meet the spirit of the one-design objectives of this Class, as well as the specific requirements specified by the Bylaws. It is also the policy of the Association to avoid a strict item-by-item definition of each piece of permissible equipment. The objective in maintaining the one-design features of the Santana 20 is to maintain an equitable base for racing in which the skill of the skipper in maintaining, tuning and sailing his

boat is tested, keeping in mind the additional features of the Santana 20 as a family cruising boat, and as a handicap racing boat .

ARTICLE II - ELIGIBLE YACHTS

A yacht shall be eligible only if it has been issued and holds a currently valid "Certificate of Measurement and Registration."

ARTICLE III - DESIGN, CHARACTERISTICS, AND EQUIPMENT

- 1 . No mold of the Santana 20 may be produced without the express permission and approval of the W.D. Schock Corp.
- 2 . Except as stated in these Bylaws, changes in the design characteristics and equipment of the Santana 20 without prior express approval in writing by the Governing Board of the Association shall be illegal and any Santana 20 yacht incorporating such changes is ineligible for racing and membership in the Association.
- 3 . The following alterations and equipment will be allowed:
 - a) A boom vang, so long as it is not operated by a winch, is mechanical (not hydraulic), and is above deck.
 - b) A block and tackle backstay adjuster, with no winches or magic boxes allowed, that is above deck (unless allowed by Measurer's Ruling #25)
 - c) A spinnaker pole track on the mast with a maximum height of 65-1/2" from butt of mast.
 - d) Bow pulpits, stern pulpits, lifeline, stern rails and other hand and toe rails.
 - e) Main Cunningham.
 - f) Jib or genoa cunningham, which must be above deck.
 - g) Two suits of sails (i .e . main, 110 jib, 150 genoa and spinnaker) in the first year and one suit each thereafter, and no more than one suit of sails (i .e . main, jib, genoa and spinnaker) may be carried on board during any given day's racing.
 - h) Mainsail reefing equipment.
 - i) One jib or genoa halyard and one spinnaker halyard.
 - j) Genoa reefing equipment.

- k) Main boom preventers.
 - l) Windows in sails.
 - m) Hiking stick.
 - n) A fraculator line may be attached to the mast and/or led to the cockpit for the purpose of pulling the mast forward when sailing downwind. It is illegal to use a line as an adjustable forestay upwind.
- 4 . The following equipment will not be allowed:
- a) Shroud release mechanisms except for aft lowers.
 - b) Slotted jib stay system.
 - c) Hydraulic jib stay or back stay adjuster.
 - d) Through-hull fittings which would increase the speed potential of the boat, except for knot meters.
- 5 . Hardware may be substituted for reasons of safety and convenience if the substituted hardware provides the same function as the original hardware and does not provide any additional function.
- 6 . The genoa sheets must be led to the standard genoa tracks; no barber hauling shall be allowed, except for the spinnaker sheet and guy. When using a class legal jib, an optional inboard jib track may be used in place of the standard genoa track. This inboard jib track may be mounted anywhere between the mast and the chain plates but cannot extend forward of the mast and can be no longer than 24 inches. The lead blocks may be ratchet-type blocks on a slide.
- 7 . Additional alterations or equipment for the handling of sails, lines, sheets or normal sailing gear provided these materials or equipment in no way add to the speed potential of the sails, hull or rigging are allowed. As example, bags for halyard tails, winch handle holders, additional non-skid on the deck and hatch.
- 8 . Bin, bunk and floorboards may use modified materials and may be either removable or fixed.
- 9 . The hull, keel and rudder may not be altered in any manner except as provided in this section:

- a) The hull, keel and rudder may be smoothed and made fair within the following provisions and material may be added to the hull, keel and rudder to fill depressions provided that after any such work the rudder and keel must meet the manufacturer's specifications.
 - b) The gap between the top of the rudder and the hull and between the front edge of the rudder and the rudder post may be filled with any material, provided this material does not extend out from the profile or section of the rudder. Under no condition may the profile of the rudder be extended in any other direction.
- 10 . The traveler on any Santana 20 may be positioned between 53-1/4" and 43" from the center of the rudder post to the center of the traveler.
- 11 . The bail on the boom can be positioned between 68" to 77-3/4" from the rear of the mast section.
- 12 . It will be acceptable to either cover the scuppers or fill them and reroute the drains to the transom or to the engine mount exit as long as the cockpit will drain.

ARTICLE IV – SAILS

- 1 . The intent of the rules is to discourage rule-beating sails. Therefore, any change which is not established practice or specifically covered by the sail plan and measurements is considered illegal until a ruling has been obtained by the Chief Measurer and Governing Board of the Association.
- 2 . The mainsail is to be marked with the approved Santana 20 Class insignia: a script "S" and the block number "20." The identifying letters and figures are to be red and shall conform to the design shown on the sail plan. The outside dimensions of the "S" shall be 18 inches high by 20 inches wide. For winged keel type Santana 20s, the addition of an 8" high red script "W" to the lower right of the standard "S" will distinguish its type from the fin keel. The racing numbers shall be 12 inches in height and placed on each side of the sail below the insignia and near the leech. The spinnaker shall be marked on both sides with numbers which correspond to those on the main sail. These numbers shall be a minimum of 12 inches in height.

- 3 . The color of the Santana 20 insignia on the National Champion's sail may, at his or her discretion, be gold as shall the year of his victory. Upon winning the Class Championship Regatta more than once, a gold chevron approximately six inches in length shall be added to the sail below the Santana 20 insignia.
- 4 . All sails shall be stamped on the tack of the sail by the Fleet Measurer with a miniature of the S-20 insignia. The Fleet Measurer shall include, within the insignia, his initial and the date the sail was measured. The Chief Measurer shall issue these stamps to all certified Fleet Measurers. In addition, all sails shall have the Santana 20 Royalty Tag permanently affixed on the tack. Sails not stamped with the official stamp, dated and signed by the Fleet Measurer, and without the Royalty Tag, shall be considered illegal and shall disqualify the boat from racing eligibility.
- 5 . The purchase and/or use of new sails by Santana 20 Class sloop owners shall be limited to one suit in any calendar year since purchase of the boat, except that one additional suit may be purchased for any yacht during its first sailing season, unless the owner already has in his possession one or more suits of sails at the time of acquiring the boat . This rule shall apply to one genoa per year, one jib per year, one main per year, and one spinnaker per year.
- 6 . Members who are new boat owners, or owners purchasing new sails shall be eligible to race, excluding major class championships, with sails which are not measured and stamped by the Fleet Measurer for thirty (30) days following purchase date of said sails. The sails shall, however, be subject to measurement and the competitor subject to protest and disqualification should the sails appear and prove to be outside the tolerance and spirit of these rules.
- 7 . Use of the spinnaker pole and guy shall comply with current US Sailing rules .
- 8 . There shall be four (4) battens in the leech of the mainsail, evenly spaced so as to divide the leech into five (5) equal parts (measured along mainsail leech measurement line) .
- 9 . Battens for all mainsails shall not be limited by length, thickness, or types of construction material, but shall be restricted in width to 1 .25 inches maximum. If any batten extends beyond the fair curve of

the leech, the girth measurements are to be taken from a straight line connecting the batten ends. Battens may not be adjusted while racing.

10 . The maximum dimensions of the mainsail shall be as follows:

Leech - 25 feet 6 inches; 1/4 Girth - 3 feet 2 inches;
1/2 Girth - 5 feet 0 inches; 3/4 Girth - 6 feet 4 inches
(All measurements not including bolt rope.)

11 . The head of the mainsail, measured from the aft edge of the luff rope to the aft edge of the headboard, shall not exceed six (6) inches.

- a) All measurements are to be made with only enough pull to eliminate wrinkles. The leech shall be measured in a straight line between top forward corner of headboard and projected clew. The leech shall be a fair curve and, if leech is a straight line between battens, the intersection of these straight lines shall fall on a fair curve.
- b) Cross Measurement - Determine 1/2 girth of luff by folding sail until top forward corner of headboard is even with the projected tack. Determine 1/2 girth of leech by folding sail until top forward corner of headboard is even with projected clew. The 1/2 girth measurement is between these two points, excluding bolt rope. Determine 1/4 girth of luff by folding sail until top forward edge of headboard is even with luff mid-girth. Determine 1/4 girth of leech by folding sail until top forward edge of headboard is even with leech mid-girth. The 1/4 girth measurement is between these two points, excluding bolt rope. Determine 3/4 girth of luff by folding sail until the projected tack is even with luff of midgirth. Determine 3/4 girth of leech by folding sail until the projected clew is even with leech mid-girth. The 3/4 girth measurement is between these two points excluding bolt rope.
- c) The main sail shall be set within the bands, as indicated on the Measurement Certificate, on the spars at all times while racing.

12 . Maximum dimensions on the jib shall be as follows:

Luff - 24 feet 6 inches; Foot - 10 feet 0 inches; Leech -
21 feet 10 inches; LP - 8 feet 11 3/4 inches

- a) The minimum LP dimensions shall be 7 feet 4 inches.
 - b) The minimum luff length shall be 22 feet 4 inches.
 - c) All measurements to be made with only sufficient pull to remove wrinkles and to be made from projected point of edges. (See Item Article VII .14.) Leech shall not exceed a straight line between head and clew but may be reversed or fall inside of a projected straight line if desired.
 - d) There must be a minimum of eight (8) hanks on the luff.
 - e) Up to a maximum of 3 equally spaced battens of any length will be allowed in the jib to extend the life of the sail.
- 13 . Maximum dimensions of the genoa shall be: Luff - 24 feet 6 inches; Foot - 13 feet 2 inches; Leech - 23 feet 4 inches; LP - 12 feet 2 7/8 inches
- a) The minimum luff length shall be 24 feet 0 inches and the minimum mid-girth shall be 5 feet 4 inches. The mid-girth shall be the distance from the midpoint of the luff to the midpoint of the leech.
 - b) The minimum LP dimension shall be 11 feet 9 inches and is meant to eliminate smaller genoas.
 - c) The measurement for genoa dimensions shall be taken in the same manner as the measurement for the jib dimensions.
- 14 . The maximum dimensions of the spinnaker, which must be of a woven generic spinnaker material, and weigh not less than 37 grams per square meter of finished spinnaker fabric, shall be as follows:
 Leech - 24 feet 6 1/4 inches; Foot - 14 feet 8 1/8 inches;
 Girth - 14 feet 8 1/8 inches
- a) All measurement to be made with only sufficient pull to remove wrinkles and made to extreme edges of cloth.
 - b) There may be a retrieving line from the center of the spinnaker.
- 15 . The head of the jib and genoa shall be the highest point of the sail not including any eye by which to attach the halyard if such eye extends past the sail itself. It shall have a maximum width of 2 1/2 inches including the bolt rope, measured at right angles to the luff. If the head has been rounded off, then the measurement shall be taken at the point where the extended line of the luff and leech are even with the very uppermost part of the sail. The tack shall be the point

of intersection of the line of the luff with the line of the foot. The clew shall be the point of intersection of the line of the leech with the line of the foot.

- 16 . Sails that have at least two (2) measurement stamps from previous Class Championship regattas are deemed legal without additional measurement. They are still subject to protest and re-measurement.

ARTICLE V - RACING RULES

- 1 . The number of persons racing in a Santana 20 sloop shall be a minimum of two (2) or a maximum of four (4).
- 2 . Every race in a series must be completed with the same number of crew aboard as started in the first race of such series.
- 3 . Hiking is not permitted. All crew members shall keep their hips inside the deck area of the boat and the angle of the torso shall not exceed the vertical or extend beyond the side of the boat. No trapezes or other special hiking equipment may be used. Normal offshore stanchions and sheets and a strap affixed to the cockpit seat may be used for support while meeting the above basic rules. Safety harnesses may not be used as a hiking assist. It is illegal to initiate a roll tack or gybe using the standing rigging (upper or lowers shrouds).

ARTICLE VI - SANCTIONED EVENTS

- 1 . The Class Championship Regatta, all regional championships, and all district championships shall be conducted only with the sanction of the Governing Board and in accordance with rules and regulations established by the Governing Board, including rules establishing qualifications for entry fees and fleet quotas.
- 2 . Fleet events shall be sanctioned by Fleet Officers.
- 3 . Fleet quotas for a Class Championship Regatta or District or Regional Regatta shall be filled by Fleets in accordance with Fleet rules, subject to the rules and regulations of the Association.
- 4 . The Class Championship Regatta shall be conducted at a place and date determined by the Governing Board.
- 5 . A Class Championship Regatta shall not be conducted in consecutive years at the same location. Deviation from this rule must be approved by the governing board.

- 6 . The Class Championship Regatta shall be conducted in accordance with the "HANDBOOK FOR CONDUCTING THE CLASS CHAMPIONSHIP REGATTA." Deviations from any rules outlined in the handbook shall be approved by the Governing Board.
- 7 . Eligibility requirements to participate as helmsman for the Class Championship Regatta shall be that they be a member, either Regular or Associate, in good standing with the Santana 20 Class Association prior to the first official race of the regatta. The helmsman must qualify in one (1) class sanctioned event prior to the Class Championship.
8. For all Class Championship Regattas and as an option for other Class sanctioned events, all entered Santana 20 Class sloops shall be required to float to official floatation lines or weigh a minimum of 1530 pounds and must be measured with all standard sailing gear including all standing and running rigging;
- one (1) suit of sails (i.e. one main, one jib, one genoa, and one spinnaker)
 - the yacht's Measurement Certificate
 - all required floorboards, binboards, and hatches
 - one personal floatation device for each crew member
 - one throwable flotation device
 - a whistle or horn
- a) Additional ballast as necessary shall be in the form of non-consumable, non-wearable items and must be approved by the Measurer and carried for the duration of the regatta. The additional ballast shall be registered on the boat's Measurement Certificate.
- b) Official float lines must be applied using an approved Class template and must be visible for the floatation test to be valid. The float line marks shall be above the point on the hull or rudder indicated by the template. Sailing gear may be moved fore or aft to level the boat in order to get both float marks to touch the water. In the absence of a template, an unofficial float line can be applied using these approximate numbers:
- 5" up from the bow knuckle and parallel to the waterline

- 5" down from the hull on the trailing edge of the rudder with the rudder in its normal position.
- a) If there is a discrepancy between these numbers and the template, the template shall have precedence.
 - b) Weight Method: The boat shall be suspended from a crane scale and weight reading taken. The weight of the lifting harness shall be subtracted from the reading.

9. The Fin Keel and the Winged Keel will race in the same division at all sanctioned events. In Regional and District level events five (5) or more entries of each division shall constitute separate starts; and if less than five of either division are entered, the two divisions shall be started together but scored separately. In the Class Championship Regatta, the two divisions shall have separate starts with a minimum of five entries being required to constitute a division.

Measurer's Rulings

- 1 . Spinnaker reaching struts, etc. The spinnaker guy is not to be considered a sheet for purposes of Article III .6, (Design, Characteristics and Equipment of the Association's Bylaws). Accordingly, the spinnaker guy does not have to lead to the genoa track but may lead through a reaching strut or to a block, bulkhead, or hook mounted other than the genoa track.
- 2 . Aft lower shrouds:
 - a) The aft lower shroud is optional and need not be fitted, may be fitted permanently, or fitted in a manner that is adjustable so long as the dimensions given in this rule are maintained.
 - b) The aft lower shroud shall be attached to the mast at the same location as the intermediate lower shroud as shown on the measurement certificate.
 - c) The maximum that the rear lower shroud may go aft is 15 inches from the back side of the chain plates. This position is measured by projecting the aft lower shroud to intersect the deck.
 - d) All mounting points of the aft lower shroud must be located on a line 12 1/2 inches inboard from the outboard edge of the deck non-skid. The inboard measurement of the mounting line is determined by measuring at right angles from the deck non-skid to the mounting line at both the forward and aft ends.
- 3 . Internal hand holds, inspection holes, inspection ports, winch handle pockets and storage cuddies are permitted in vertical surfaces of the cockpit.
- 4 . Spinnaker launching and retrieving tubes are not legal.
- 5 . The hanks on the jib must be attached to the headstay when the jib is in use.
- 6 . Through-hull kelp removing devices are not legal.
- 7 . Internal tangs in the mast are not within the one-design concept of the Santana 20 Class Rules and are not legal.
- 8 . Inspection holes in the V-berths are legal but covers must be kept in place while racing.

- 9 . Bainbridge 404 Dynac cloth is not acceptable for the spinnaker because its base fabric is 1/2 oz. material.
- 10 . Roller furling gear is not legal.
- 11 . The bearing point of the spinnaker halyard when held taut at right angles to the mast may not be higher than 23 feet 8 inches from the bottom of the mast extrusion. Any exit arrangement attachment points shall not extend out from the mast farther than 7/8"
- 12 . Reefing the working jib is not legal.
- 13 . "Membership" in Article XI .7 of the Articles of Association is deemed to mean membership in good standing with dues current.
- 14 . When using a cunningham on the jib or genoa, the tack of the sail must be attached to the stemhead fitting of the boat and the cunningham must have a separate eye in the sail.
- 15 . The intent of Article IV .2 of the Bylaws is not to prohibit the measurement of specific items at the Class Championship Regatta.
- 16 . A mainsheet system that does not employ the traveler and changes the positioning points on the boom for the mainsheet attachment is illegal.
- 17 . The intent of the spreader design is that the spreaders should be in a straight line (perpendicular to the centerline of the hull). Therefore, it is illegal to employ swept back spreaders.
- 18 . Any protrusion in front of the rudder, in this case intended to keep kelp from getting caught on the rudder post is illegal because it is an alteration of the hull shape.
- 19 . Tubes used to guide the backstay lines forward to the middle of the cockpit are legal.
- 20 . It is legal to use a line to position the genoa cars; however, in keeping with the spirit of the rules, the system shall be simple and shall not use magic boxes, winches, or hydraulics.
- 21 . In Article VII .5 of the Bylaws, "sailing season" is interpreted to mean the first calendar year in which the boat is owned.
- 22 . It is legal to use a shackle no more than 3" in height in place of the bow fitting hooks so long as the shackle adds no additional function or advantage.

- 23 . Any type of stiffening or strutting for the purpose of stiffening the deck or hull is illegal.
- a) The lone exception to this ruling is that a short bracing line may be run from the underside of the aft end of the checkstay track down and forward to the lower main bulkhead. This will prevent the deck from lifting and developing a weak spot when the aft lowers are brought into tension. However, it is imperative that the lower bulkhead attachment point be longitudinally in-line with the checkstay track attachment point, be well-backed, and be low enough that the mounting bolts go through both the main bulkhead and through the aft vertical wall of the V-berth box structure. This will ensure that the minimal load is spread evenly through as much of the structure as possible.
- 24 . It is interpreted that Article VI .7 of the Bylaws means that the helmsman must satisfy the regatta requirements and that he must have satisfied them as helmsman.
- 25 . "Classic" decked Santana 20's may attach their backstay at the base of the transom and may run their backstay adjustment lines through the transom and into the cockpit through the cockpit's rearmost vertical wall only, so long as the material used in the transom-cockpit passage is rigid, well-sealed, and does not compromise the strength or watertight integrity of the hull .
- 26 . The Santana 20 Class is not an international class recognized by the I.Y.R.U. Therefore, I.Y.R.U. Rule 25 .1 does not apply. Under Rule 25 .2, the Santana 20 Class authority requires only racing numbers, no national letters. In the case of yachts from countries which do not use the sequential numbers from the Santana 20 Class, they may use their own numbering system if used in conjunction with their national letters.
- 27 . The use of Mylar cloth for spinnakers is illegal.
- 28 . The transom radius shall be 5/16". No sharpening of the radius shall be permitted.
- 29 . The use of carbon fiber spinnaker poles is illegal.
- 30 . Repairs to the boat are legal if they meet the following conditions:

- a) the repair does not impart an obvious improvement, relative to a factory original Santana 20, in the overall performance of the boat.
 - b) the materials and reconstruction methods used in making the repair shall be comparable to those used in the original boat (aka "faithful reproduction") except:
 - 1) when a boat damaged during competition would be prevented from returning to the same competition due to the lack of time, lack of appropriate materials, or lack of expertise to carry out a "faithful reproduction."
 - 2) when alternative materials and reconstruction methods are commonly available and offer a lower total repair cost as compared to a "faithful reproduction."
- 31 . A batten may be attached to the masthead crane at one end and the back stay at the other to help clear the leach of the main.
- 32 . Non-wire/rod backstays and checkstays are Class legal. However, the upper/lower shrouds and the forestay will remain of wire/rod construction.

Fleet Measurer's Manual

INTRODUCTION

This manual was prepared to aid the Fleet Measurer in performing his job. The information regarding exact measurements in this manual is strictly advisory. The Class Bylaws, Measurement Certificates and Chief Measurer's Rulings are the official specifications of this Class. The methods described may be used even if the specific dimensions change.

There are several typed of one design rules. Some, such as the Lido 14 are very restrictive. In this class, every part of the boat is rigorously measured. Another type, known as a "developmental class" is much less restrictive. An example of this would be the Star boat. In this class, the hull and sail are closely measured, but all other hardware is totally free of measurement.

Our class falls somewhere between these two. The sails are strictly measured, as you will see. The hull, except keel and rudder, is not as closely measured. This is because the boats are all built by one manufacturer and because it is more difficult to alter the hull shape or weight than, say, a Lido. The keel and rudder are more closely measured because they can be easily altered for a significant speed advantage.

The running rigging is more closely regulated than the hull. This is done to keep the Santana 20 from becoming so expensive or complex that it is out of reach for the average sailor.

The foregoing explains the factors a measurer must consider when measuring a boat. First, those things which affect the speed potential of the boat, the sails, and the keel and rudder configuration are closely measured. The running rigging and any owner added "go fasts" are also looked at closely in order to hold down expense and complexity. If the Fleet Measurers do their jobs well, we will have a healthy, growing class for years to come. **SAILS** Before you start measuring sails, read the Class Rules and Chief Measurer's Rulings. These should be fully understood before you start. As was stated in the introduction, the Santana 20's sails are strictly measured with no plus allowance. This is done because the sail is the engine that drives our boat and even a minor variation would give unfair advantage and destroy the one design idea.

Now that you are ready to start measuring, you will need a steel tape of at least 50 feet. Secondly, you will need a large, flat clean area to lay the sail. Finally, a checklist such as Exhibit A on Page 55 comes in handy.

This checklist contains all the required measurements and the box next to the dimension may be checked off when the measurement is taken. In addition, this sheet should be kept as a permanent record to assure that only the proper number of sails are measured per year.

MAIN

- 1 . Check for Royalty Tag, which should be sewn near the tack.
- 2 . Check insignia and numbers. These should be of the size specified in Article VII .2. In addition, check the color: all insignias, but the class champions, must be red.
- 3 . Check the battens, which should be as shown on Exhibit A on Page 55.
- 4 . The headboard should be measured as shown below:
Error! Reference source not found.
- 5 . Next, lay the main out and with your helper, and pull the leech enough to remove the wrinkles. This does not mean that you have to remove the creases caused by the hard filler used on the sailcloth. The points used to measure the leech are shown below:

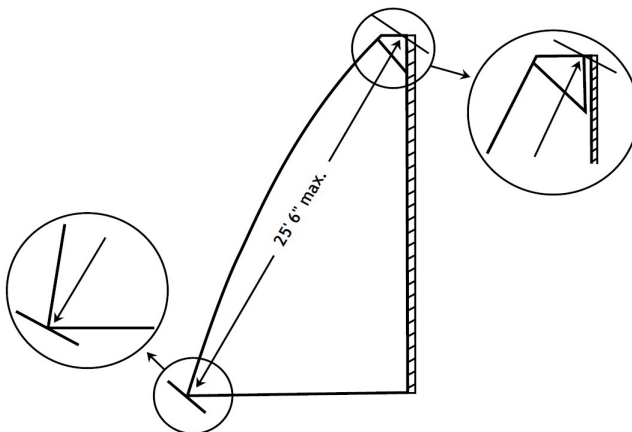

The cross measurement is made by first folding the sail to establish the midpoint. This is done by first folding the sail head to tack as shown below:

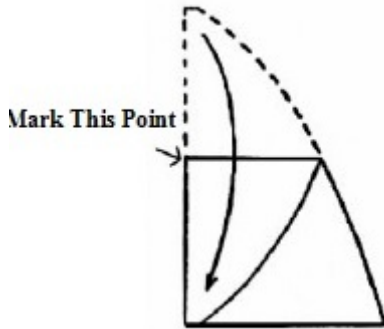

Mark the luff with a pencil .

Next, establish the midpoint of the leech by folding the head to the clew as shown below:

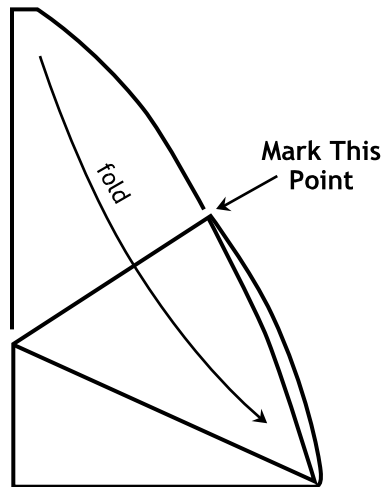

The cross measurement is from the outside edge of the leech at your mark to the outside edge of the luff, excluding the luffrope

6 . Finally, after the sail measures up to your requirements, stamp the tack with the Santana 20 stamp and initial and date the stamped.

JIB AND GENOA

- 1 . When measuring the jib and genoa luffs, enough tension must be applied to remove any wrinkles caused by luff rope tension.
- 2 . Note that measurements on the jib and genoa are taken from the projected points on the tack and clew and the highest point of the sail for the head as stated in Article IV. 15 of the Bylaws.

Error! Reference source not found.

- 3 . The LP measurement is made by placing the end of your tape at the projected clew. Then swing the tape in an arc over the luff until you obtain the minimum measurement. See below:

Error! Reference source not found.

Note that there is a minimum LP measurement and a minimum luff length on both the jib and genoa. There is also a minimum mid-girth on the genoa

- 4 . Make sure there are a minimum of 8 hanks and that the leech is at maximum a straight line from head to clew. See below:

Error! Reference source not found.

- 5 . Stamp, sign, and date the sail if it has passed your scrutiny.

SPINNAKER

- 1 . With the spinnaker, extreme care must be used to put only enough pressure on the sail to remove the wrinkles. With the light nylon that spinnakers are made of, you can stretch them out of measurement very easily.
- 2 . Measurements are made from projected points.
- 3 . Measure both leeches, as they are inter-changeable.
- 4 . Obtain a sample of % oz. Nylon from a local sail maker for comparison with the spinnakers you measure. This method will assure that all spinnakers are made of 3/4oz. Material.
- 5 . Foot and maximum girth measurements are the same and should be taken at the extreme edge of the spinnaker. This includes the tape sewn on the edge.
- 6 . If the sail measures in, stamp, date, and sign.

HULL

If the sails are the engine that drives the boat through the water, then the hull represents resistance to this progress. Because of this, the hull is closely regulated. The area which can yield the greatest advantage is fairing of the keel and rudder. This is because of the relatively large surface area they represent for their small overall size.

The dimension for the hull and rigging are on the Measurement Certificate. To measure the thickness of keel and rudder, build a tool cut of two moveable squares and ½" inch angle aluminum.

Error! Reference source not found.

1. Measure the keel and rudder from the forward top edge to aft at a point halfway. Make a mark.
2. At this mark, measure down 3 inches and 20 inches, make a mark at these points.
3. Now, with your tool, open the jaws so that they just touch each side of the keel or rudder. Care should be taken that the tool is square to the keel or rudder to avoid a faulty reading. Note that there is a plus or minus 3/8" inch tolerance in these measurements.
4. To check for hollowing, lay a straight edge, such as a heavy yardstick, along the side of the keel and rudder.
5. If all these measurements add up, the hull has passed.

RIGGING

The standards for rigging measurements are included in both the Bylaws and on the Measurement Certificate. When measuring the rigging, keep in mind that, in this case, we are trying to equalize the potential speed of the boats AND the pocketbooks of the owners. This is why twin headstays or hydraulics is forbidden.

1. Measure from the headstay clevis pin that attaches it to the seam, to the forward edge of the mast.
2. Measure the maximum height of the spinnaker track from the base of the mast to the top of the useable track. Do not include the one or two inches which extend beyond the screw attaching it to the mast, which is not useable.
3. Measure the aft lower shrouds. This is done because many are installed or modified by owners. These may be placed a maximum of

15 inches aft of the chainplates. If they are on slides, this is the maximum that the slide will allow the shroud to be aft of the chainplate. Secondly, check the shroud's location from the edge of the non-skid, which should be a maximum of 12" inches.

- 4 . The black band on the boom is measured from the aft edge of the mast to the forward edge of the black band. The mast head black band may be checked by using the main halyard. Have a helper raise the tape to the lower edge of the black band while you stand far enough away so that you can see when the edge of the tape is just at the black band.
- 5 . You will notice that an item-by-item check of the standing rigging is not suggested. This is because most owners will not alter it due to the small advantage to be gained. In addition, as you are making the other measurements, you can give these a cursory check to determine if anything has been altered. If you see something that looks strange, measure it.

CLOSING

As you gain experience measuring your fleet's boats, you will find it becomes less and less of a chore. You will also find that as you gain experience, it is easier to make judgments on what is or is or is not in the spirit of the Class Rules.

If for any reason, a disagreement over a measured item cannot be resolved between the fleet measurer and the member, refer it to the Chief Measurer. These items will be presented to a Board of Directors meeting for a final decision.

Remember, we all have an equal stake in keeping our boats truly one design. The rule is the reason that racing our boats is so exhilarating, and it is what will protect our investment. If older boats stay competitive with new boats, their value will not depreciate as drastically as, say, last year's IOR speedster.

This manual is meant to be a working guide. In order to make it better, and to help other measurers, and suggestions or problems should be shared with all fleets through the Chief Measurer

EXHIBIT A Sail Measurement Worksheet

BOAT # _____ OWNER'S

NAME _____ DATE _____ BATTENS – Max.

Length BATTENS – Max. Length

TOP 20-3/8" _____
 MIDDLE 22" _____

MIDDLE 22" _____
 BOTTOM 20 3/8: _____

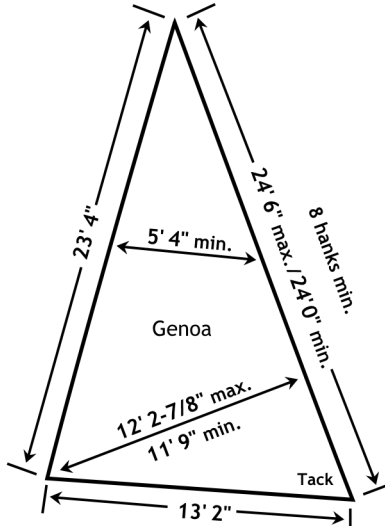
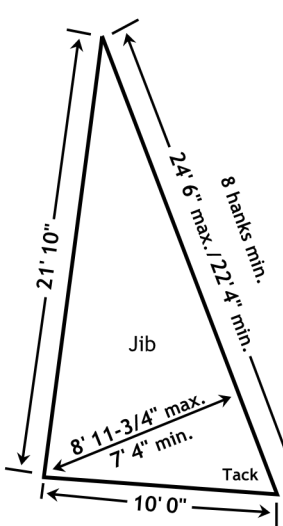
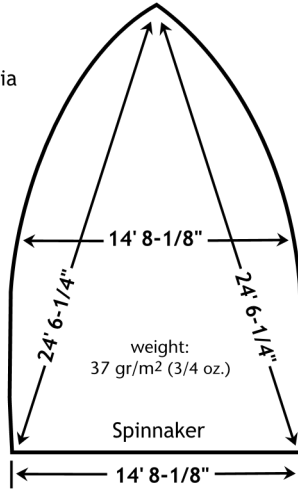
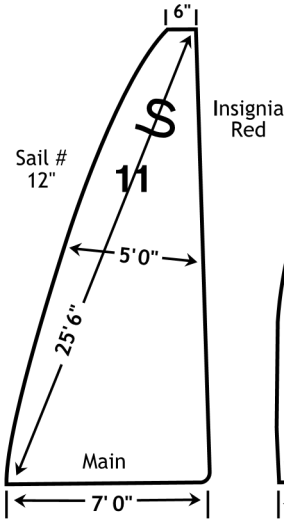

Santana 20 Winged Keel Dimensions

Error! Reference source not found.

(Note: *Santana 20 Characteristics*, page 55)

Guidelines for Conducting Class Championship Regattas

SECTION I — INTENT

The intent of this handbook is to provide rules and guidelines to aid the Governing Board, Vice President, Regatta Chairman, and hosting yacht club in providing the Santana 20 Class Association a quality annual yachting event.

The goals of the Class Championship Regatta are:

- a . Promote the Santana 20 Class and encourage participation.
(To promote youth participation, the board is offering up to three junior teams - 18 yrs. or under - scholarships to cover cost of entry fee ((check with Board to confirm availability))).
- b . Honor contribution to the Santana 20 Class.
- c . Award participation and good fair consistent sailing.
- d . Select a Class Champion

The spirit of the regatta should maintain an open communicative atmosphere in order to train, rather than intimidate those new to the Class or to the sport of yachting. Execution of the regatta must meet the standards appropriate for an International Championship,

with strict adherence to the US Sailing Racing Rules of Sailing, rules of the Class and Race Committee instructions to ensure that everyone takes home something meaningful.

SECTION II: — RULES FOR CONDUCTING THE S20 CLASS CHAMPIONSHIP REGATTA.

- Every attempt shall be made to sail at least 5 races. 3 races shall constitute a regatta. No throw outs.
- The course shall be windward – leeward.
- Race management and execution shall be done in a professional manner, with the on-the-course decisions regarding shifting winds, shortening courses, and other modifications being made at the discretion of the race committee to best facilitate a fair and safe regatta.
- All marks shall be rounded to port.
- The 720 rule shall be, in accordance with the USSA Racing Rules of Sailing, the default penalty. Should the hosting fleet decide to use some alternative penalty, it shall be so stated in the racing instructions.
- When 40 or more boats register, membership may decide to split the boats into two fleets. If so, two qualifying races shall be sailed to split the fleet. The top 50% approximately of the qualifiers shall race the championships in the Gold Fleet, the remainder in the Silver Fleet. The split will be at the discretion of the Board of Directors of the Santana 20 Class Association.
- If less than 40 boats, two official practice races shall be sailed. Qualifying/practice races will be conducted just as championship races. This should be a time for both committee and racers to practice racing exactly as the championship racing will be.

SECTION III – GUIDELINES FOR ACCOMPLISHING VARIOUS TASKS ASSOCIATED WITH THE CLASS CHAMPIONSHIP REGATTA

The Board of Directors should select sites for the championships carefully. Bids which offer the Class the best opportunity to achieve

our goals should be chosen. A Class representative should be appointed to act as Regatta Chairman for each championship.

A letter of agreement with the host club should be written by the Regatta Chairman or designated representative. This letter should include regatta deadlines set for the Regatta Schedule, Regatta Announcement, and Race Instructions. It should also define the contribution of the Class Association to the Regatta. This letter should be approved in advance by the Board of Directors of the Santana 20 Class Association as should each of its individual parts.

The Board of Directors should work to develop a care of YRU Judges who have:

- (a) Experience with our championship Regatta.
- (b) Knowledge of our rules and the Santana 20.
- (c) Credibility with our members.

The Regatta Chairman, together with the hosting yacht club and the local fleet, should form committees as outlined below. A statement detailing regatta finances should be turned into the Class Association Treasurer within sixty (60) days following the regatta.

SECTION IV – COMMITTEE RESPONSIBILITIES

RACE COMMITTEE/MARKS AND BOAT

Among others, the committee's duties include:

- (a) Draft race instructions and course sheets.
- (b) Provide the following: Shapes, pennants, timers, air horn, bullhorn, shotgun, wind vane, communication device(s), recording forms, marks, etc.
- (c) Supervise stake boats in setting of marks.
- (d) Run races, recording starters and finishers, noting protests.
- (e) Work with Protest Committee to post scores (both preliminary and final).
- (f) Examine safety requirements, issue appropriate instructions and ensure enforcement.
- (g) Supervise Race Committee bulletin board, providing notices, protests, etc.
- (h) Provide rescue/stake boats and committee boat.

- (i) Plan for the operation, storage, maintenance, and fueling of these boats.
- (j) See to set up and return of equipment.

PROTEST COMMITTEE

Among others, the committee's duties include:

- (a) Obtain commitments from enough experienced people to make up Protest Committee. Solicit help from past cadre of judges.
- (b) Provide rule books, protest forms, books of appeals, boat models, etc. for processing protests.
- (c) Arrange a time and place for all protests to be filed and a suitable place to hold hearings.
- (d) Plan for an effective means to notify individual protesters, protestees, & witnesses when their protest session begins.
- (e) Coordinate with scorers to convey results as they are reached.

REGISTRATION CHECK-IN

Among others, the committees' duties include:

- (a) Gather information to be included in the Regatta Announcement and arrange for the Announcement to be approved by the Board of Directors of the Santana 20 Class Association, publish and send to members at least 60 days prior to the event. Include schedule of events, description of club facilities, local accommodations, campgrounds, parks fees, deadlines, special instructions, safety requirements, etc.
- (b) Assemble material to be included in the check-in packet, such as course sheets, sailing instructions, participation awards, and banquet tickets.
- (c) Compile and update at check-in a list of Regatta participants, including crews, committee personnel, volunteers, etc. Copy and distribute to each skipper and committee chairman.
- (d) Sell Regatta T-shirts, banquet tickets, etc.
- (e) Set up registration area, have cash box, records, packets, tickets, measurement checklists, etc.

- (f) Provide for a general information center the rest of the week and place for notices, etc.

MEASUREMENT/CHECK-IN

Among others, the committee's duties include:

- (a) The Class Chief Measurer is responsible for the measurement of boats and should coordinate with the Measurement Committee to ensure an acceptable process.
- (b) A measurement checklist can be prepared and included in the check-in packet. Each skipper can have each item signed off by the appropriate measurement official then return the completed checklist to the committee.
- (c) One full day should be scheduled for measurement. This is a time of stress for many participants. Enough help should be on hand to make the day go smoothly and efficiently.
- (d) Prepare an agreement form for charter boats. Line up the needed number of boats, arrange for their delivery, measurement and return.
- (e) Arrange for the availability of spare parts. A local dealer or marine hardware store may arrange to have these parts on hand with advance notice. Items most often needed include halyards, Windex's, Hexaratchets, lines, bungee cord, winch handles, anchors and other safety equipment.

SOCIAL/PUBLICITY AWARDS

Among others, the committee's duties include:

- (a) Providing social activities for participants, guests, and committee members, which encourages them to mingle, share experiences, and enjoy one another is the objective.
- (b) Breakfasts, hors d'oeuvres after the races, dinners, social mixers, special activities, parties, fireworks show's—all are successful ideas from the past. And by adding to these, we can continue to improve our regatta.
- (c) Use our members and their special talents. Solicit the help of individual fleets – have them host, plan, and/or finance certain functions. Local businesses might also sponsor kegs of beer or happy hours. Clubs might host parties or special entertainment.

Arrange for group accommodations and go for cut rates. Be creative and cost effective!

- (d) Schedule the Annual Meeting for a convenient time so everyone will be encouraged to attend.

PUBLICITY

Among others, the committee's duties include:

- (a) Pre-race publicity is centered on getting out information early. Contestants, their crew, and guests must plan ahead for vacation. Boats must be prepared, sails made and measured, and budgets planned in order to be able to attend. It is of the utmost importance that an official rough schedule be in the Class Newsletter six (6) months prior to the event. It all starts with the site selection at the preceding Annual Meeting and continues through the publication of the Regatta Announcement. The Social/Publicity Chairman must drive the initial stages of planning into an early decision as to when the Regatta will take place.
- (b) Media coverage requires advance planning. Most magazines have racing calendars. Find out what is needed and get us on them. Invite reporters to the Regatta, have media boats, arrange for a photographer (volunteer, if possible).
- (c) Solicit at least two participants in advance to write up the event. Plan for pictures and give it all to the editor for our newsletter and to the magazine.
- (d) Plan for videos. It is fun to watch all the action back at the club.

AWARDS

Among others, the committee's duties include:

- (a) Awards need not be elaborate. Money is more effectively spent improving the event for all comers. The satisfaction of performing well is the real award – try to keep it simple and elegant.
- (b) Awards should go to the top five skippers and crews of both the Gold and Silver fleets and to the Winged Keel division.
- (c) Participation awards should be commemorative in nature.

- (d) Awards for contributions to the Class, gag awards, and other awards are great for the Association and are encouraged.

SECTION V – REVISIONS OF THIS SECTION

**REGARDING GUIDELINES FOR CONDUCT OF
CLASS CHAMPIONSHIP REGATTAS**

The retiring Vice President will present to the Governing Board recommendations for revision of this section at the completion of the championships. The Board will consider recommendations from the Jury Chairman as well. The approved revisions to this section will be included in the upcoming Yearbook

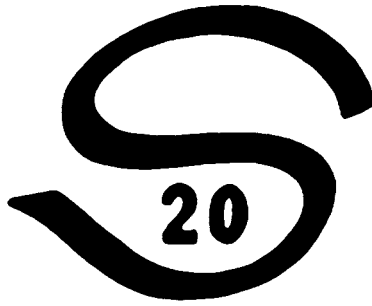

www.S20.org